

8 7 6 5 4 3 2 1

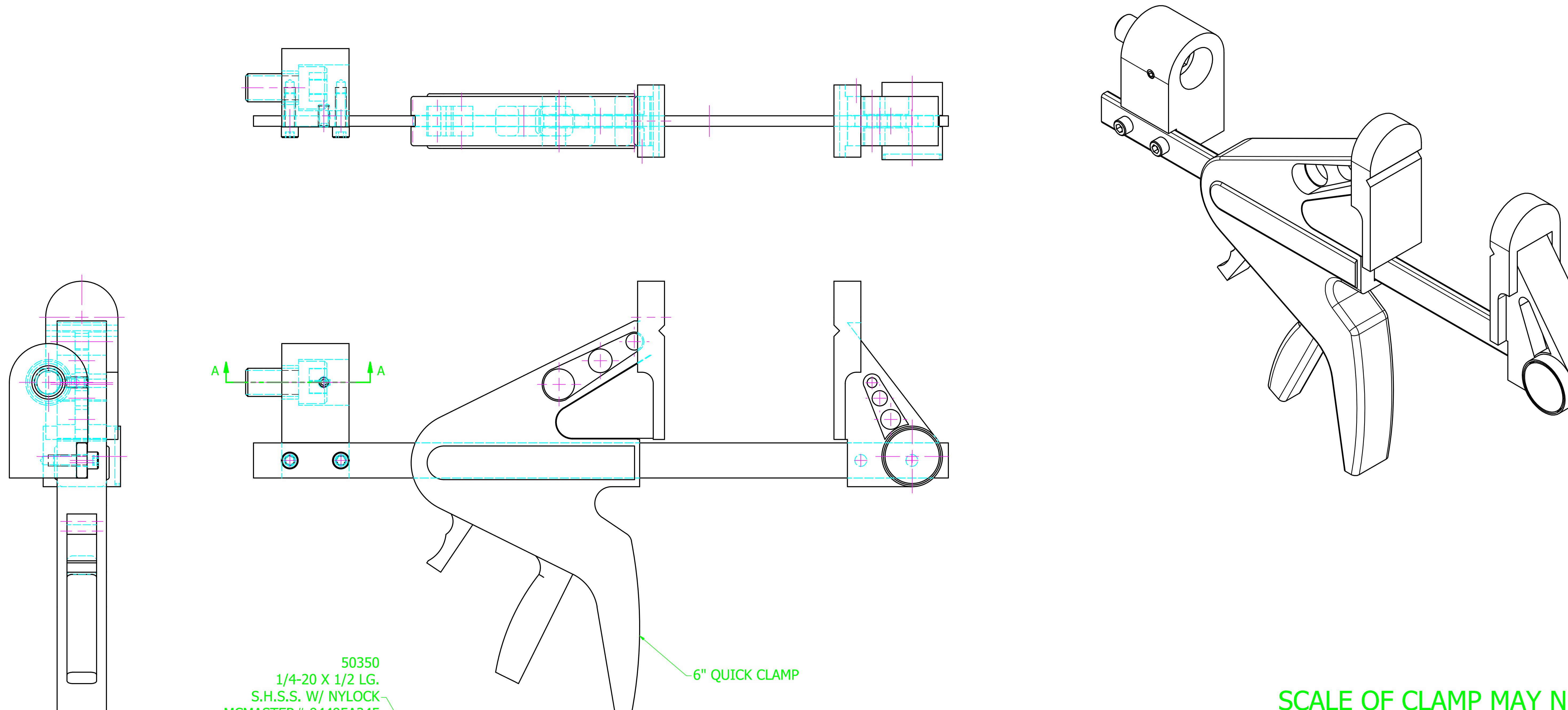

50350
1/4-20 X 1/2 LG.
S.H.S.S. W/ NYLOCK
MCMASTER# 94495A245
(1) SUPPLIED

50578
M16 X 40mm LG.
S.H.C.S. (1) SUPPLIED

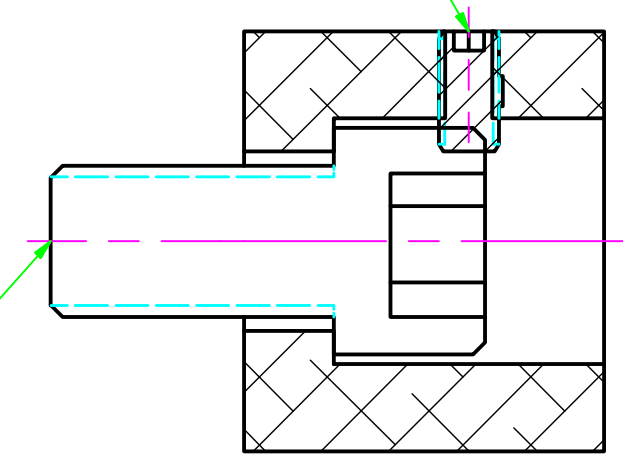

SECTION A-A

6" QUICK CLAMP

SCALE OF CLAMP MAY NOT
BE CORRECTLY REPRESENTED
DUE TO SUPPLIER CHANGES

MATERIAL:

BREAK ALL SHARP CORNERS
MARK DETAILS WITH PART No.
UNLESS OTHERWISE SPECIFIED

STANDARD TOLERANCE
UNLESS OTHERWISE SPECIFIED
2 PLACE DEC. ± .03
3 PLACE DEC. ± .005
4 PLACE DEC. ± .0005
ANGLES ± 1°

REV	DESCRIPTION	DATE	DWN	CHK
A (1)			X	X

REVISIONS

Automated Drive and Design, LLC

DESCRIPTION
2" METRIC PRODUCT QUICK CLAMP ASSEMBLY

SCALE: FULL
SHEET SIZE: D

DRAWN: JS DATE: 03/23/11
CHECKED: X DATE: _____
APPROVED: X DATE: _____

No. OF SHEETS: _____ PART No.: 50588
SHEET No.:

8 7 6 5 4 3 2 1